



PRODUCT DATA SHEET

M-TDV MULTIPOINT TUBE DIVERTER VALVE

UP TO 14 ROUTES THROUGH ONE COMPACT DIVERTER VALVE

The DMN-WESTINGHOUSE M-TDV is a multiport tube diverter valve for pneumatic conveying systems handling powders and pellets. It enables product flow to be diverted from one line to multiple destinations or converged from multiple lines into a single line. Available in configurations with from 4 up to 14 ports, the M-TDV offers a compact alternative to systems built with multiple two-way diverters in series.

WHY CHOOSE THE M-TDV?

- Up to 14 routes through one compact valve
- One valve for multiport diverging or converging product flows
- Only two smooth bends in the product path
- Fewer diverters, control outputs, connections, and service points
- Helps reduce product degradation, pressure loss, and equipment wear
- Rigid frame design for reliable alignment under full piping load
- Inspection and maintenance without removing the valve from the line, or the need to remove factory piping
- Hygienic execution available for demanding production environments



A SMARTER ALTERNATIVE TO MULTI-DIVERTER LAYOUTS

Traditional multi-diverter layouts can require several two-way diverters in series. That adds more valves, actuators, controls, connections, and service points. The M-TDV brings those routing functions into one compact unit. In a 1-to-14 configuration, one compact M-TDV can replace up to 13 two-way diverters, helping simplify the system from design and installation through to operation and maintenance. Fewer controlled units mean fewer points of complexity. Fewer service points mean less maintenance effort and less downtime over time. The result is a cleaner, more compact, and more practical system layout.

ONLY TWO SMOOTH BENDS IN THE PRODUCT PATH

Every extra diversion step in a conveying system adds another direction change. More direction changes can increase product degradation, pressure loss, and wear on system components. The M-TDV limits the product path to two smooth bends through a single valve. Its internal rotating swan neck guides the product smoothly between the inlet and the selected outlet for diverting duty, or from the selected inlet to the outlet for converging duty. Exact alignment between the swan neck and the selected port creates a direct, controlled flow path, helping protect product quality and supports reliable switching between positions.

RIGID UNDER REAL INSTALLATION LOAD

The M-TDV is designed with a highly rigid frame structure that remains stable when plant piping is connected to all ports. This helps maintain proper alignment under real installation load, supports smooth switching, and reduces the risk of operational issues caused by frame deflection or misalignment.

EASIER INSPECTION AND MAINTENANCE

The M-TDV is designed for practical service access in the plant. Recommended spare parts can be replaced without removing the valve from the production line or disconnecting all connected pipework. Seals can be changed from the inside, while internal parts such as the swan neck can be removed for inspection or cleaning. This helps make service work faster, easier, and less disruptive.

HYGIENIC EXECUTION AVAILABLE

For hygienic applications, the M-TDV is available with stainless steel product contact areas, FDA-approved white EPDM inflatable seals, and EC1935/2004-compliant product contact materials. USDA-accepted versions are available where required.

KEY FEATURES

- One valve for diverging from 1 line to up to 14 destinations, or converging from up to 14 lines into 1
- Replaces a complex multi-diverter arrangement with one compact unit
- Helps reduce control outputs, connections, and overall system complexity
- Exact alignment between ports and internal swan neck
- Smooth product path with only two smooth bends
- Helps minimise product degradation, pressure loss, and equipment wear
- Highly rigid frame structure for reliable alignment under full piping load
- Compact, robust design with a small system footprint
- Designed for inspection and maintenance without removing the valve from the line, or the need to remove factory piping
- Internal access for seal replacement, cleaning and inspection
- Suitable for pneumatic conveying of powders and pellets
- Suitable for 4 to 14 ports, depending on size
- Available in sizes from 40 to 150
- Hygienic design, with USDA-accepted versions available
- EC1935/2004-compliant product contact materials and FDA-approved white EPDM inflatable seals
- ATEX 2014/34/EU certification available
- Temperature range: -20°C to +100°C
- Pressure range: -0.8 to 3 barg
- Removable covers, with transparent covers available as an option

ABOUT DMN-WESTINGHOUSE

DMN-WESTINGHOUSE designs and manufactures high-end rotary valves and diverter valves for dry bulk solids handling industries worldwide. With decades of engineering experience, application knowledge, and global support, DMN-WESTINGHOUSE delivers proven valve technology and tailored solutions focused on process continuity, product quality, reliability, and long-term performance.

SPECIFICATIONS

Pipe connection	Imperial
Maximum allowable working pressure	-0.8 to 3 barg
Allowable conveying product temperature	-20°C to 100°C (130°C for short periods only)
ATEX 2014/34 EU	Marking of the mechanical equipment II 1D/2D and II -/2G
Upwards conveying and diverging is less recommended	

TYPE	AVAILABLE SIZES						
M-TDV tube diverter valve	40	50	65	80	100	125	150
Number of ports	4 - 14	4 - 13	4 - 12	4 - 11	4 - 10	4 - 8	4 - 7

MATERIAL SPECIFICATIONS

Standard execution	Aluminium 5083 (DIN 3.3547) and Stainless steel AISI 304 (DIN 1.4301)
Dairy execution	Stainless steel AISI 304 (DIN 1.4301)
Piping	Stainless steel AISI 316L (DIN 1.4404)
Removable covers	Stainless steel AISI 304 (DIN 1.4301) or transparent PMMA (optional)
Inflatable seal	EPDM White (FDA-approved & EC 1935/2004-compliant)

DRIVE SPECIFICATIONS

SEW	Gearmotor type RF37/R DRN71M4/TF/EK8C with incremental encoder
Motor power	0.37 kW
Electrical supply	230/400 V 50 Hz
Protection	IP 55
Isolation	F

CYLINDER LOCKING PIN SPECIFICATIONS

Festo	Type ADN-50-30-I-P-A-S2-EX4
Operating medium	Air filtration lubricated or not up to 10 bar
Temperature range	-20°C to 80°C
Working pressure	5 - 10 bar

POSITION CONTROLLER SPECIFICATIONS

KEBA/LTI-LUST	Type CDB32.003
Terminal extension module	Type UM-8I4O, 2.0
Rated motor output	0.37 kW
Supply voltage	230 V 50/60 Hz
Nominal output current	2.4 A/4.3 A Peak for 30 s
Protection	IP 20
Ambient temperature	-25°C to 45°C (up to 55°C with derating)

For more information about KEBA/LTI products see:

<https://www.keba.com/en/industrial-automation/products/servo-controllers/c-line-drives-detail>

SOLENOID VALVE LOCKING PIN SPECIFICATIONS

Function	5/2 bistable version with manual control
Festo	Type MFH-5-1/4-EX
Connection	G1/4
Operating medium	Air filtration lubricated or not up to 8 bar

SOLENOID VALVE INFLATEABLE SEAL SPECIFICATIONS

Function	3/2 monostable version with manual control
Festo	Type MOFH-3-1/8-EX
Connection	G1/8
Operating medium	Air filtration lubricated or not up to 8 bar

SOLENOID COIL SPECIFICATIONS

Festo	Type MSFG-24-EX
Protection	IP 65
Socket connection	DIN 43650 form B
Standard voltage	24 VDC
Temperature range	-5°C to 40°C

PRESSURE SWITCH SPECIFICATIONS

Festo	Type PEV-1/4-B
Protection	IP 65
Voltage	Max. 125 VDC/250 VAC

PROXIMITY SWITCH HOME SENSOR SPECIFICATIONS

Function	Inductive threaded proximity switch, PNP normally closed
IFM	Type IG512A
Protection	IP 67
Voltage	10 VDC to 30 VDC

PROXIMITY SWITCH LOCKING PIN SPECIFICATIONS

Function	Magnetic reed slot mount proximity switch, normally open
Festo	Type SME-8M-DS-24V-K-2,5-OE
Protection	IP 65
Voltage	5 V to 30 V (AC and DC)

TERMINAL BOX SPECIFICATION

ROSE

Material	Polyester
Protection	IP 66



Easily change the seal without the need to remove the factory piping.



Exact alignment between ports and internal swan neck.

MEASUREMENTS

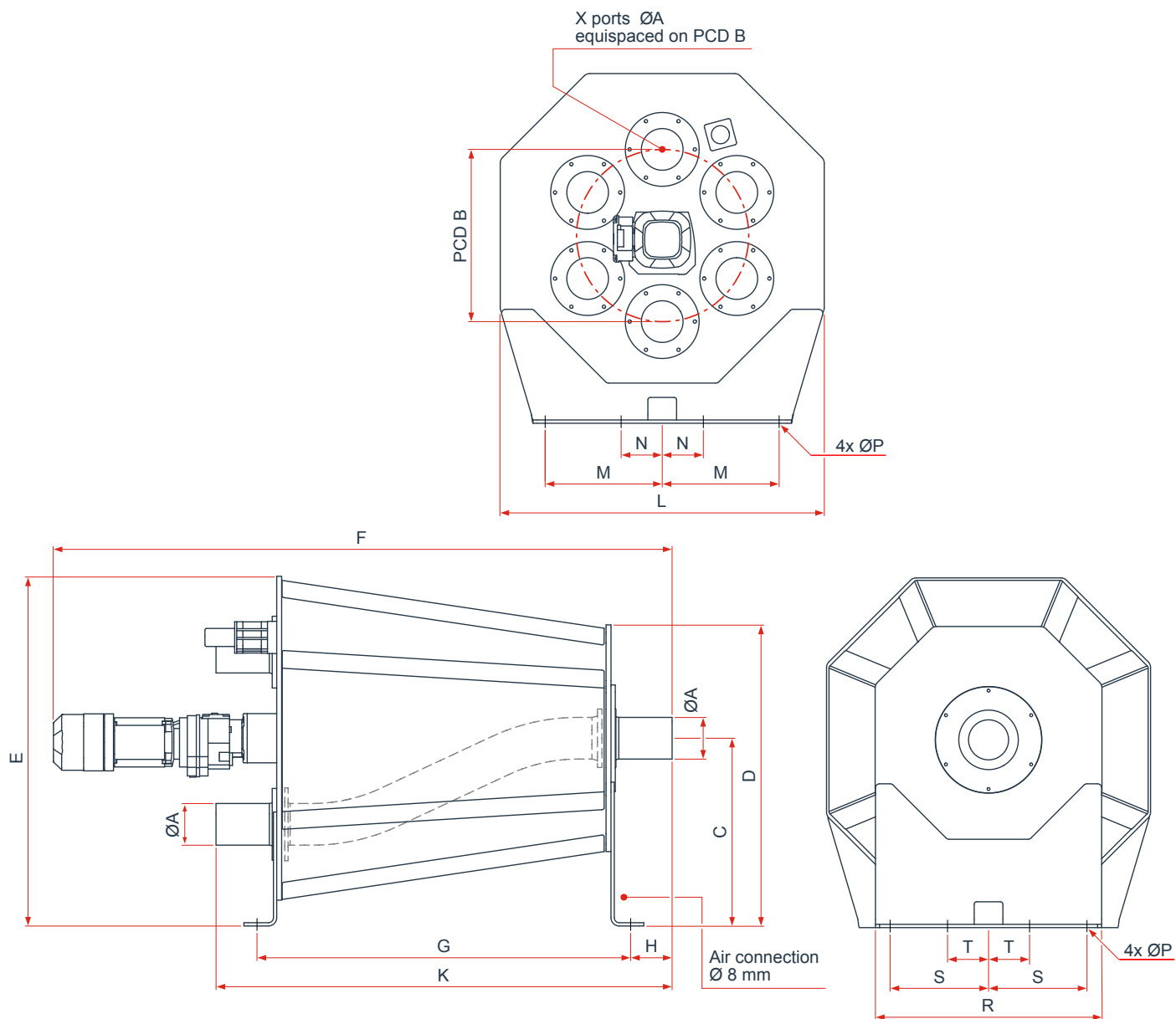

	SIZE	$\varnothing A$	X	B	C	D	E	F	G	H	K	L	M	N	P	R	S	T
SMALL MODULE	40	38.1x1.5	4-10															
	50	50.8x1.5	4-9															
	65	63.5x1.5	4-8	420	458	735	853	1510	911	102	1113	790	285	100	14	553	240	100
	80	76.1x1.5	4-8															
	100	101.6x2	4-7															
LARGE MODULE	40	38.1x1.5	11-14															
	50	50.8x1.5	10-13															
	65	63.5x1.5	9-12															
	80	76.1x1.5	9-11	600	560	858	1063	1780	1178	102	1381	1000	410	150	14	598	250	100
	100	101.6x2	8-10															
	125	129x2	4-8															
	150	154x2	4-7															

Technical modifications are possible, dimensions in mm.



DMN
WESTINGHOUSE

DMNWESTINGHOUSE.COM